

Smart Energy Controller

SUN2000-30/36/40KTL-M3



Smart

8 strings intelligent monitoring



Efficient

Max. efficiency 98.7%



Safe

Fuse free design



Surge protection

Type I + Type II

Efficiency Curve

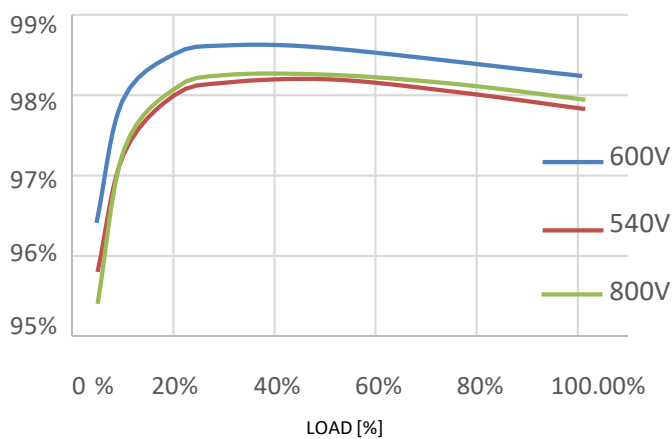

Circuit Diagram

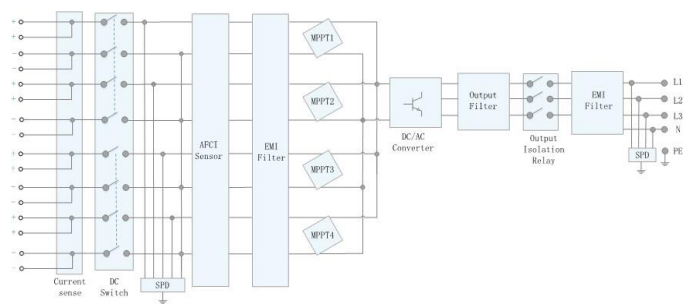

SUN2000-30/36/40KTL-M3

Technical Specification

SUN2000	-30KTL-M3	-36KTL-M3	-40KTL-M3
Efficiency			
Max. Efficiency	98.7%		
European Efficiency	98.4%		
Input			
Max. Input Voltage ¹	1100 V		
Max. Current per MPPT	27 A (per MPPT) / 20 A (per Input)		
Max. Short Circuit Current per MPPT	40 A		
Start Voltage	200 V		
MPPT Operating Voltage Range ²	200 V - 1000 V		
Rated Input Voltage	600 V		
Number of Inputs	8		
Number of MPP Trackers	4		
Output			
Rated AC Active Power	30000 W	36000 W	40000 W
Max. AC Apparent Power	33000 VA ³	40000 VA	44000 VA
Rated Output Voltage	230 Vac / 400 Vac, 3W/N+PE		
Rated AC Grid Frequency	50 Hz		
Rated Output Current	43.3 A	52.0 A	57.8 A
Max. Output Current	47.9 A	58.0 A	63.8 A
Adjustable Power Factor Range	0.8 LG ... 0.8 LD		
Max. Total Harmonic Distortion	< 3%		
Protection			
Input-side Disconnection Device	Yes		
Anti-islanding Protection	Yes		
AC Overcurrent Protection	Yes		
DC Reverse-polarity Protection	Yes		
PV-array String Fault Monitoring	Yes		
DC Surge Arrester	Yes		
AC Surge Arrester	Yes		
DC Insulation Resistance Detection	Yes		
Residual Current Monitoring Unit	Yes		
Arc Fault Protection	Yes		
Ripple Receiver Control	Yes		
Integrated PID Recovery ³	Yes		
Surge protection ⁴	Type I + II		
Communication			
Display	LED Indicators, Integrated WLAN + FusionSolar APP		
RS485	Yes		
Smart Dongle	WLAN/Ethernet via Smart Dongle-WLAN-FE (Optional) 4G / 3G / 2G via Smart Dongle-4G (Optional)		
General Data			
Dimensions (W x H x D)	640 x 530 x 270 mm		
Weight (with mounting plate)	43 kg		
Operating Temperature Range	-25°C to +60°C		
Cooling Method	Natural Convection		
Max. Operating Altitude	4000 m (Derating above 2000 m)		
Relative Humidity	0% RH - 100% RH		
DC Connector	Amphenol Helios H4		
AC Connector	Waterproof Connector + OT/DT Terminal		
Protection Degree	IP 66		
Topology	Transformerless		
Nighttime Power Consumption	≤ 5.5W		
Optimizer Compatibility			
DC MBUS Compatible Optimizer	SUN2000-450W-P2, SUN2000-600W-P, MERC-1100W/1300W-P		
Standard Compliance (more available upon request)			
Safety	EN 62109-1/-2, IEC 62109-1/-2, EN 50530, IEC 62116, IEC 60068, IEC 61683		
Grid Connection Standards	IEC 61727, VDE-AR-N4105, VDE 0126-1-1, BDEW, G59/3, UTE C 15-712-1, CEI 0-16, CEI 0-21, RD 661, RD 1699, P.O. 12.3, RD 413, EN-50438-Turkey, EN-50438-Ireland, C10/11, MEA, Resolution No.7, NRS 097-2-1, AS/NZS 4777.2, DEWA		

*1. The maximum input voltage is the upper limit of the DC voltage. Any higher input DC voltage would probably damage inverter.

*2. Any DC input voltage beyond the operating voltage range may result in inverter improper operating.

*3. SUN2000-30-40KTL-M3 raises potential between PV- and ground to above zero through integrated PID recovery function to recover module degradation from PID. Supported module types include: P-type (mono, poly).

*4. SPD Type I+II for inverters with a manufacturing date after 09/01/2024, see self-declaration for more details

Disclaimer: the preceding values are measured by an internal laboratory of Huawei in a specific environment. The actual values may vary with products, software versions, usage conditions, and environmental factors.