

LUNA2000-100KTL-M1 Smart PCS



Surge Arresters for
DC & AC



Modular Design



IP66 Protection



Ethernet
Communication



Smart Grid
Algorithm

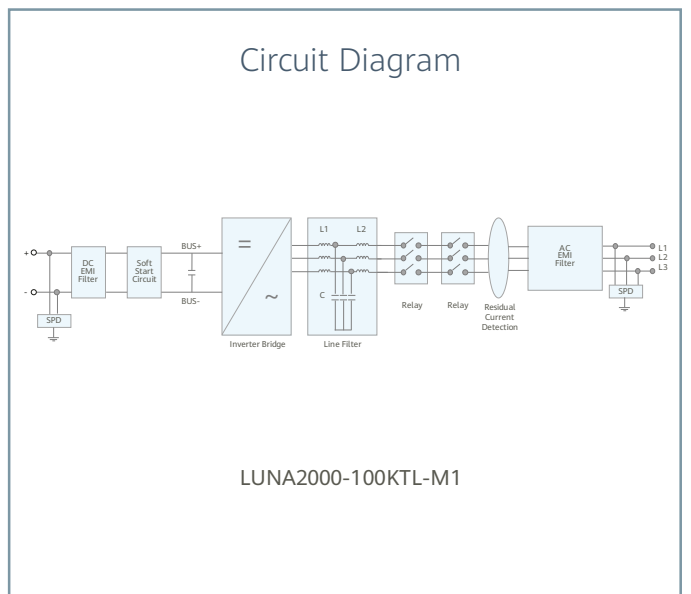
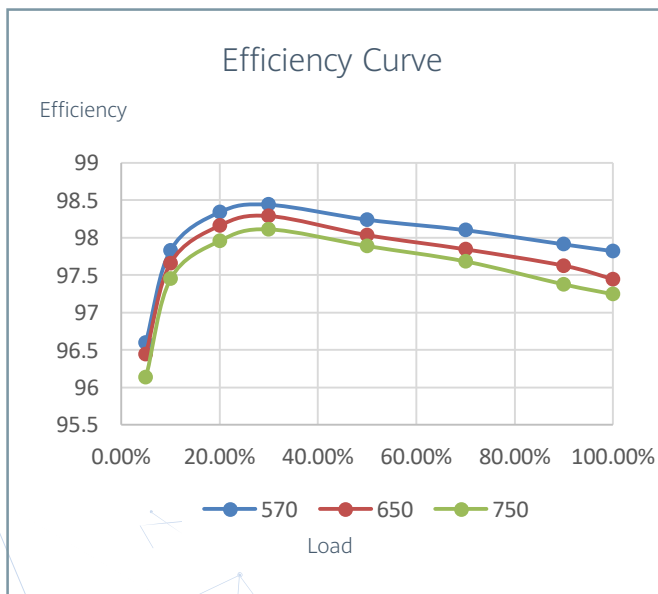

LUNA2000-100KTL-M1

Technical Specifications



Efficiency	
Max. Efficiency	98.4%
DC Side	
Rated DC Voltage	645 V
Max. DC Voltage	1,100 V
Operating DC Voltage Range	570 V ~ 1100 V
Max. DC Current	215.8 A
Max. Number of Inputs	1
AC Side	
Rated AC Active Power	100,000 W @40°C
Rated AC Voltage	380 Vac / 400 Vac / 440 Vac
Rated AC Grid Frequency	50 Hz / 60 Hz
Max. AC Current	173.2 A
Adjustable Power Factor Range	-1 ... +1
Max. Total Harmonic Distortion	< 3%
Protection	
Anti-islanding Protection	Yes
AC Overcurrent Protection	Yes
DC Reverse-polarity Protection	Yes
Insulation Resistance Detection	Yes
Residual Current Protection	Yes
DC Surge Protection	Type II
AC Surge Protection	Type II
Communication	
Display	LED Indicators, WLAN + APP
Networking Mode	Ethernet, CAN
General	
Dimensions (W x H x D)	875 x 820 x 365 mm
Weight	< 95 kg
Operating Temperature Range	-25°C ~ 60°C (Derating above 40°C)
Cooling Method	Smart Air Cooling
Max. Operating Altitude without Derating	4,000 m
Relative Humidity	0 ~ 100%
DC Connector	OT/DT Terminal
AC Connector	OT/DT Terminal
Protection Degree	IP66
Topology	Transformerless

