

# Smart String Inverter

SUN2000-36KTL



## Smart

- 8 strings intelligent monitoring and fast trouble-shooting
- Power Line Communication (PLC) supported
- Smart I-V Curve Diagnosis supported

## Efficient

- Max. efficiency 98.6%
- European efficiency 98.4%
- 4 MPPT per unit, effectively reducing string mismatch

## Safe

- DC switch integrated, safe and convenient for maintenance
- Residual Current Monitoring Unit (RCMU) integrated
- Fuse free design

## Reliable

- Natural cooling technology
- Protection degree of IP65
- Type II surge arresters for both DC and AC

# Smart String Inverter (SUN2000-36KTL)

| Technical Specifications            | SUN2000-36KTL                                                                   |
|-------------------------------------|---------------------------------------------------------------------------------|
|                                     | <b>Efficiency</b>                                                               |
| Max. Efficiency                     | 98.6%                                                                           |
| European Efficiency                 | 98.4%                                                                           |
|                                     | <b>Input</b>                                                                    |
| Max. Input Voltage                  | 1,100 V                                                                         |
| Max. Current per MPPT               | 22 A                                                                            |
| Max. Short Circuit Current per MPPT | 30 A                                                                            |
| Start Voltage                       | 250 V                                                                           |
| MPPT Operating Voltage Range        | 200 V ~ 1,000 V                                                                 |
| Rated Input Voltage                 | 620 V                                                                           |
| Number of Inputs                    | 8                                                                               |
| Number of MPP Trackers              | 4                                                                               |
|                                     | <b>Output</b>                                                                   |
| Rated AC Active Power               | 36,000 W                                                                        |
| Max. AC Apparent Power              | 40,000 VA                                                                       |
| Max. AC Active Power (cosφ=1)       | Default 40,000 W; 36,000 W optional in settings                                 |
| Rated Output Voltage                | 220 V / 380 V, 230 V / 400 V, default 3W + N + PE; 3W + PE optional in settings |
| Rated AC Grid Frequency             | 50 Hz / 60 Hz                                                                   |
| Rated Output Current                | 54.6 A @380 V, 52.2 A @400 V                                                    |
| Max. Output Current                 | 60.8 A @380 V, 57.8 A @400 V                                                    |
| Adjustable Power Factor Range       | 0.8 LG ... 0.8 LD                                                               |
| Max. Total Harmonic Distortion      | < 3%                                                                            |
|                                     | <b>Protection</b>                                                               |
| Input-side Disconnection Device     | Yes                                                                             |
| Anti-islanding Protection           | Yes                                                                             |
| AC Overcurrent Protection           | Yes                                                                             |
| DC Reverse-polarity Protection      | Yes                                                                             |
| PV-array String Fault Monitoring    | Yes                                                                             |
| DC Surge Arrester                   | Type II                                                                         |
| AC Surge Arrester                   | Type II                                                                         |
| DC Insulation Resistance Detection  | Yes                                                                             |
| Residual Current Monitoring Unit    | Yes                                                                             |
|                                     | <b>Communication</b>                                                            |
| Display                             | LED Indicators, Bluetooth + APP                                                 |
| RS485                               | Yes                                                                             |
| USB                                 | Yes                                                                             |
| Power Line Communication (PLC)      | Yes                                                                             |
|                                     | <b>General</b>                                                                  |
| Dimensions (W x H x D)              | 930 x 550 x 283 mm (36.6 x 21.7 x 11.1 inch)                                    |
| Weight (with mounting plate)        | 62 kg (136.7 lb.)                                                               |
| Operating Temperature Range         | -25°C ~ 60°C (-13°F ~ 140°F)                                                    |
| Cooling Method                      | Natural Convection                                                              |
| Max. Operating Altitude             | 4,000 m (13,123 ft.)                                                            |
| Relative Humidity                   | 0 ~ 100%                                                                        |
| DC Connector                        | Amphenol Helios H4                                                              |
| AC Connector                        | Waterproof PG Terminal + OT Connector                                           |
| Protection Degree                   | IP65                                                                            |
| Topology                            | Transformerless                                                                 |
|                                     | <b>Standard Compliance (more available upon request)</b>                        |
| Certificate                         | EN 62109-1/-2, IEC 62109-1/-2, EN 50530, IEC 62116, IEC 60068, IEC 61683        |
| Grid Code                           | IEC 61727, AS/NZS 4777.2, G59/3, PEA, MEA, Resolution No.7, VDE 0126-1-1        |

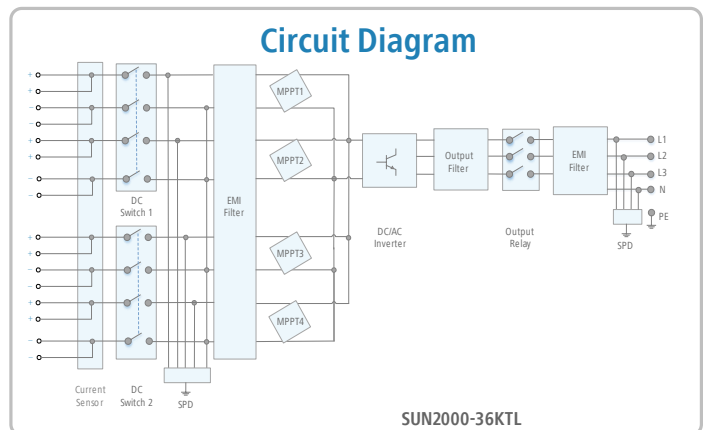
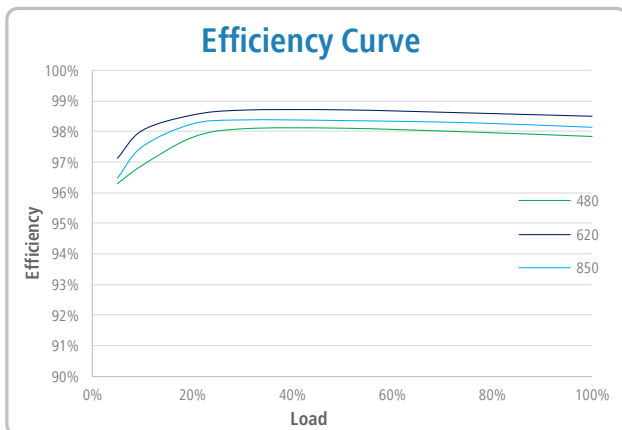

The text and figures reflect the current technical state at the time of printing. Subject to technical changes. Errors and omissions excepted. Huawei assumes no liability for mistakes or printing errors. For more information, please visit solar.huawei.com. Version No.:01-(201808)